

Ezi Reach
SLIDING CARGO TRAYS

Fitting Instructions Dual/Space Cab Utes

To install your cargo tray please follow the instructions below. We recommend undertaking the installation with two people, and allowing 45mins to an hour for completion.

Step 1:

Unpack the tray and remove all of the accessories and fittings included.

Fittings included in the pack to install the tray should be;

- 6x Bolts (A)
- 6x Spreader Brackets (B)
- 6x Washers (C)
- 6x Nylock Nuts (D)

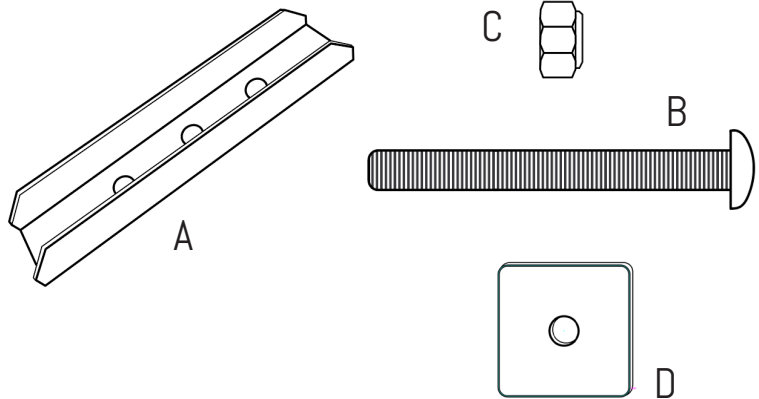

Step 2:

Lift the handle of the cargo tray and pull to fully extend the tray. Remove the four transit bolts that are securing the tray to the pallet.

Step 3:

Lift the cargo tray off the pallet.



Step 4:

Place the tray onto the vehicles tailgate (we recommend 2 people) & carefully slide the tray into the tub between the wheel arches.

We recommend that you place something over your tailgate to avoid damage whilst positioning the tray.

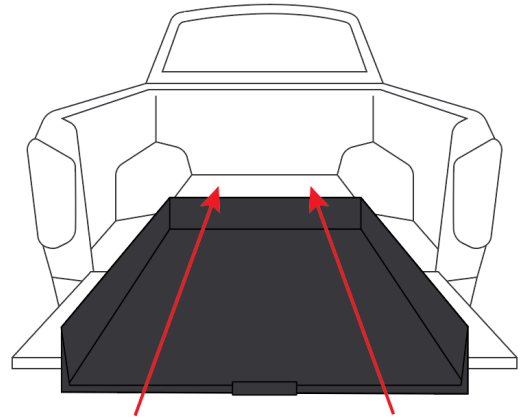

Step 5:

Place the rubber strips provided underneath the cargo trays sub-frame (this is optional if you have a tubliner). This provides extra stability for the tray.

TIP: Some vehicles may need an additional half strip of rubber at the tailgate end to raise the front of the cargo tray up, helping to clear the tailgate when the tray is extended with a heavy load.

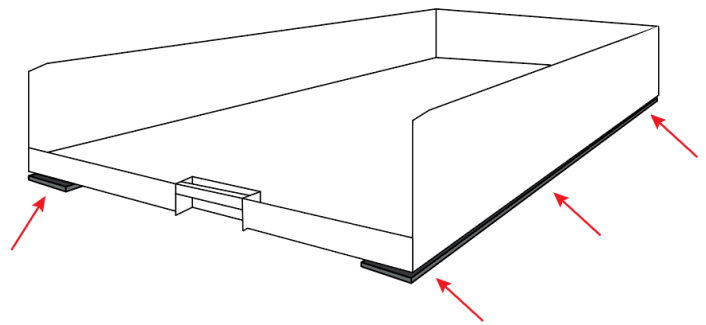

Step 6:

Adjust the position of the cargo tray so that it is central side to side at both the back and front. There should be a minimum gap of 1cm between the trays handle and the tailgate when the tailgate is closed.

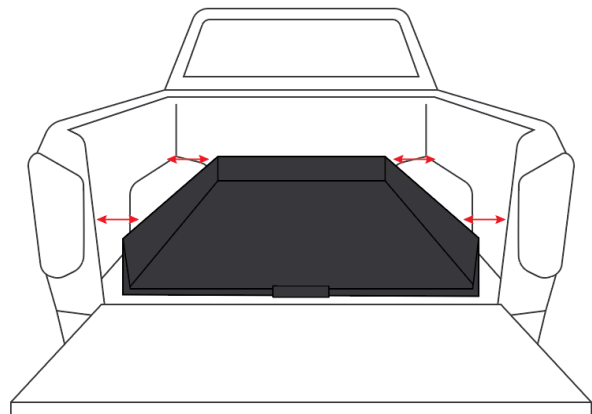

Step 7:

Lift the handle & carefully slide the cargo tray out, approximately half way to expose the holes for the fittings. Select 2 holes (1 on either side of the sub frame) close to the back end of the tray.

Note: A visual check underneath the vehicle is required to ensure these holes dont interfere with wiring etc.

Drill the holes being careful not to move the trays position.

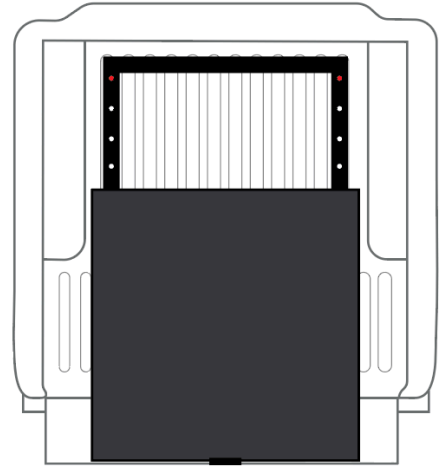

Step 8:

WARNING:

Twist drills move rapidly when breaking through sheet steel.

Once drilled, remove all swarf and paint the holes to prevent rusting. Place the bolts (A) supplied through the holes from within the tub. From underneath the tub, place the spreader brackets (B) over the bolts and fasten loosely using the washers (C) and nylock nuts (D).

Note: the spreader brackets (B) should be at a 90 degree angle to the tubs ribs.

Tighten the bolts using a drill from the inside of the tub.

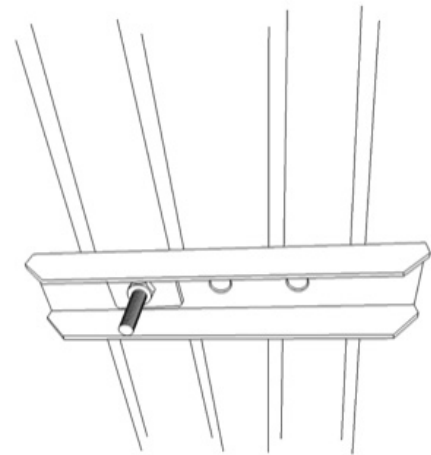

Step 6:

Select 2 hole positions towards the middle of the sub frame and repeat Steps 7 & 8.

Carefully extend the cargo tray fully and repeat Steps 7 & 8 for two holes towards the tail gate end of the subframe.

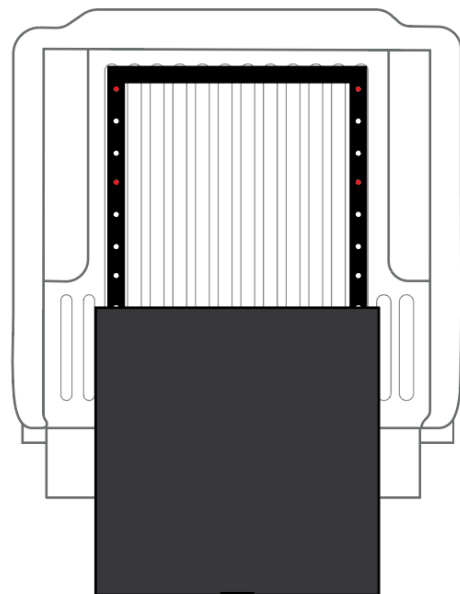

Step 9:

Clean away any swarf from within the tub as this may hinder the movement of the cargo tray.

Test your cargo tray by sliding it in and out of the vehicle a few times. Make sure nothing interferes with the movement, the tray should move freely if installed correctly.

TIP: To operate your cargo tray squeeze the handle and pull the tray towards you. To engage the locking system, simply let go of the handle and the tray will lock into position every 10mm once it's cleared the tailgate.

Side Box Fitting Instructions

It is recommended that the cargo tray is fitted to the vehicle before the side boxes are assembled.

If Side Boxes were purchased the following should be included in your order;

- 1x left side box (E)
- 1x right side box (F)
- 1x back support bar (G)
- 3x M6 16mm zinc dome head (H)
- 8x M6 10mm zinc dome head (I)
- 11x M6 Nylock nuts (J)
- 8x M4 Hex head screws (K)

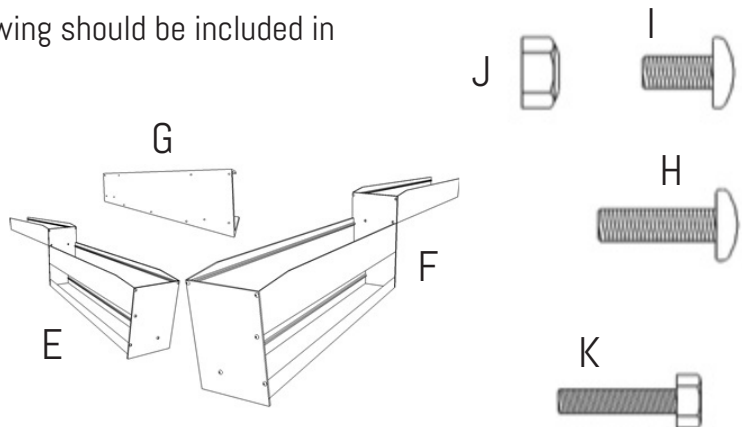

Step 1:

Position the back support at the back of the tray and loosely fit the 3x M6 16mm screws (H) and 3x nylock nuts (J). The head of the screws should be on the inside of the tray.

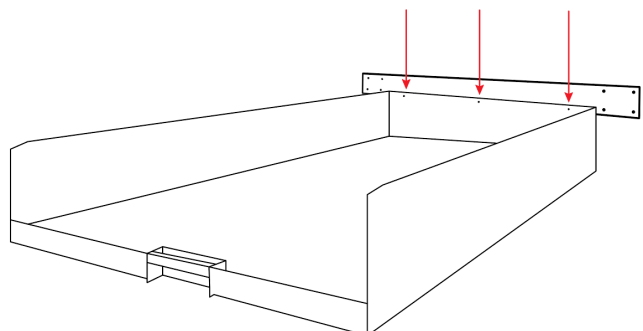

Step 2:

Position the right side box (F) against the outside of the tray on the right hand side. Using 4x M6 10mm dome head screws (I) and 4x nylock nuts (J) loosely attach the side box. The heads of the screws should be on the inside of the tray.

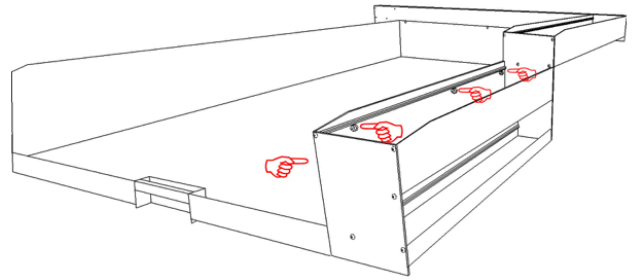

Repeat this step with the left side box (E).

Step: 3

Fit 4x M4 Hex head screws through the back of the support bar and into the screw flutes found in the back of the right side box (F).

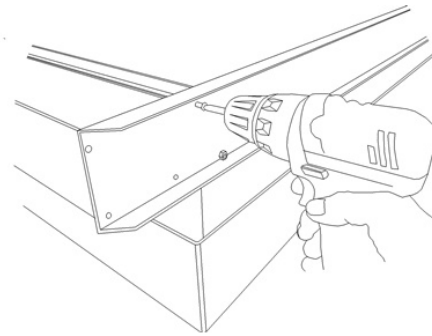

Repeat this step with the left side box (E).

Step: 4

Check that all parts are aligned correctly and then tighten all the fittings.

Congratulations!

You've now completed the installation of your Ezi Reach Sliding Cargo Tray.

If you have any issues with installing your tray please dont hesitate to contact us for assistance.

Phone: 0434 744 903

Email: info@ezireach.com.au

Web: www.ezireach.com.au